

MITSUBISHI DIESEL ENGINE

For Generator Application

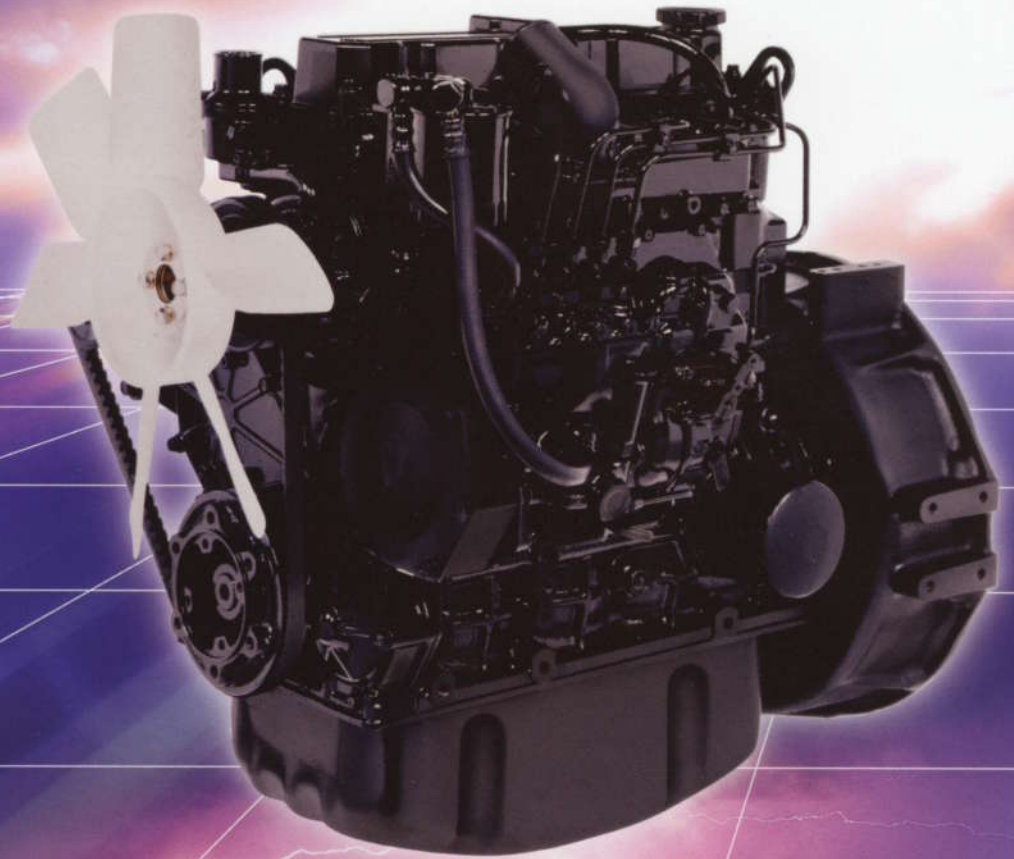

MITSUBISHI
HEAVY INDUSTRIES, LTD.

ADVANCED TECHNOLOGY

Mitsubishi is most pleased to present you herewith our diesel engine line-up with latest technology and innovation for your own power need.



Low Noise

Powerful, but as quiet as possible...one of Mitsubishi's development target is to lower the engine noise level through the research and development to support the trend of regulations for the comfort of human's environment.

Clean Diesel

To create the sustainable power source is the highest mission for Mitsubishi. To comply with latest and future emission regulations is one of the ways for engine manufacturers to protect the environment. As a long-term solution for your power need, Mitsubishi's technology supports the human activity with philosophy of "ECOSILENT ENGINE" now and in the future.

Low Fuel Consumption

Mitsubishi's engine with low fuel consumption adds the value to your product and supports the operation at end users' premises in years. In combination with Mitsubishi-made turbocharger with world top class technology, we contribute to the saving of both financial and environmental resource during its life even further.

Easy Maintenance

The accessibility to serving points with ease helps end users' regular maintenance during its full operation. To be a reliable partner of the human activity, Mitsubishi's design with durability supports your product in the market now and in the future.

ECOSILENT ENGINE

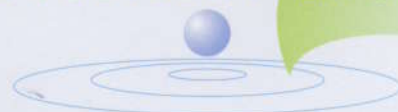

"ECOSILENT ENGINE" REPRESENTS MHI'S PHILOSOPHY TO DEVELOP THE MOST ENVIRONMENTALLY-FRIENDLY ENGINE FOR ALL LIVES AND OUR EARTH.

MITSUBISHI DIESEL ENGINE LINE-UP (GENERATOR)

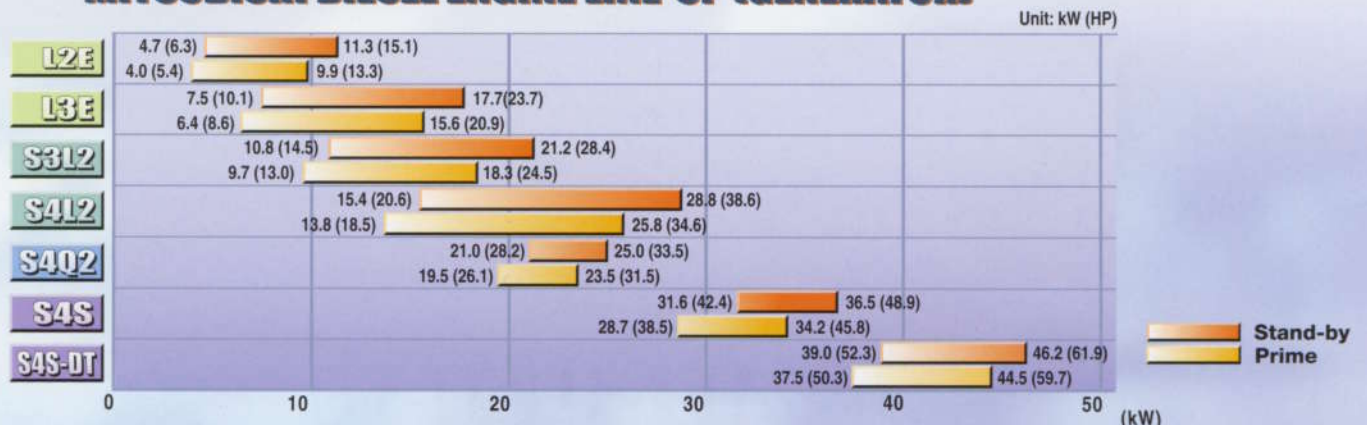

Dimensions (Unit: mm)



L2E/L3E

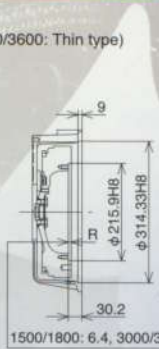
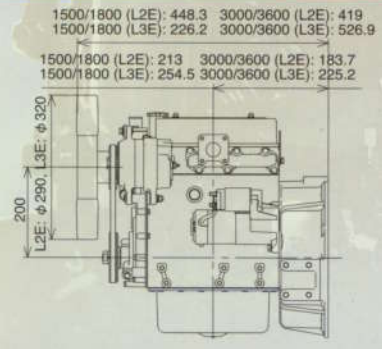
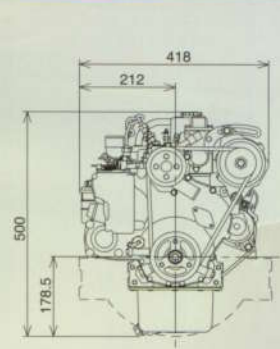

1500/1800 (L2E): 448.3 3000/3600 (L2E): 419
 1500/1800 (L3E): 226.2 3000/3600 (L3E): 526.9

1500/1800 (L2E): 213 3000/3600 (L2E): 183.7
 1500/1800 (L3E): 254.5 3000/3600 (L3E): 225.2

Flywheel: SAE #6.5
 Flywheel housing: SAE #5 (3000/3600: Thin type)

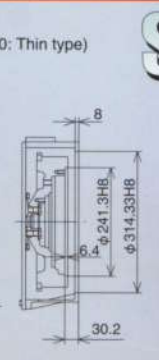
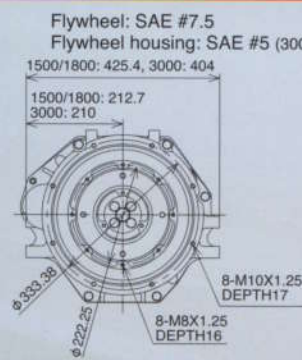
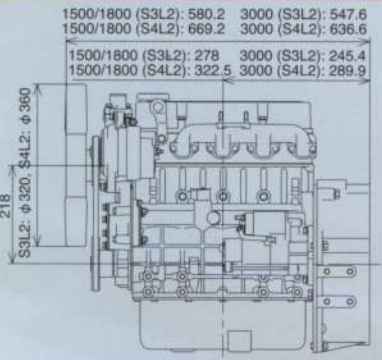
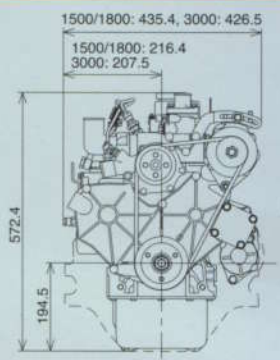

S3L2/S4L2



1500/1800 (S3L2): 580.2 3000 (S3L2): 547.6
 1500/1800 (S4L2): 669.2 3000 (S4L2): 636.6

1500/1800 (S3L2): 278 3000 (S3L2): 245.4
 1500/1800 (S4L2): 322.5 3000 (S4L2): 289.9

Flywheel: SAE #7.5
 Flywheel housing: SAE #5 (3000: Thin type)

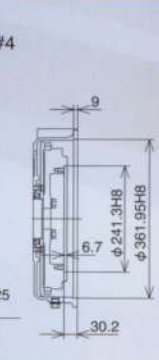
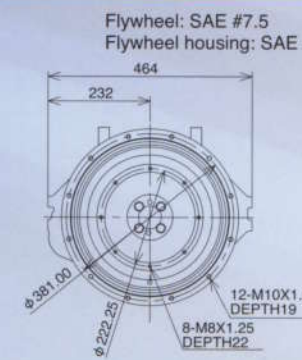
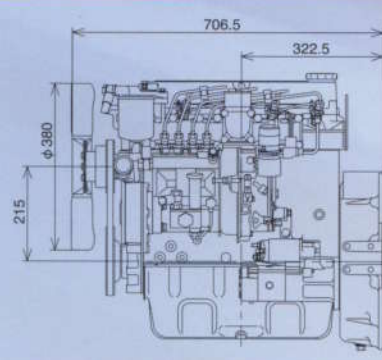
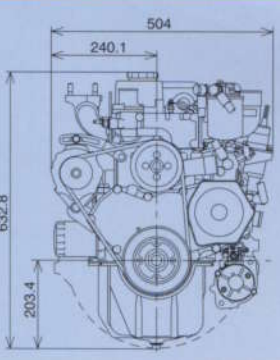

S4Q2



Flywheel: SAE #7.5
 Flywheel housing: SAE #4

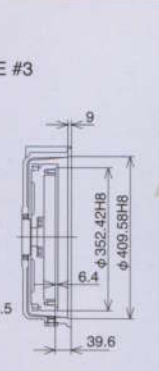
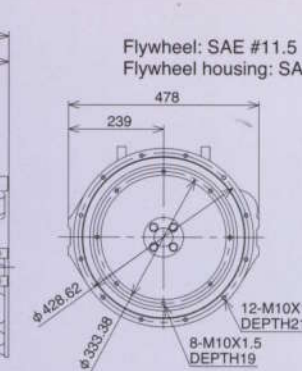
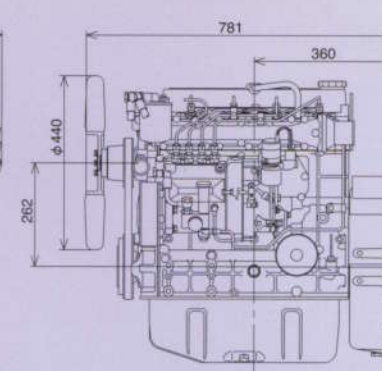
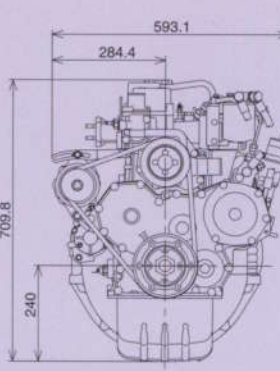

S4S



Flywheel: SAE #11.5
 Flywheel housing: SAE #3

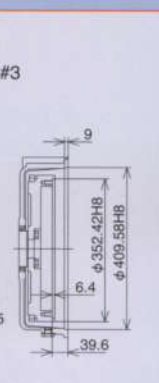
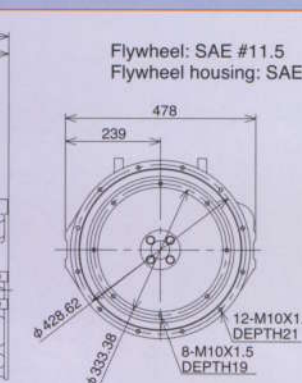
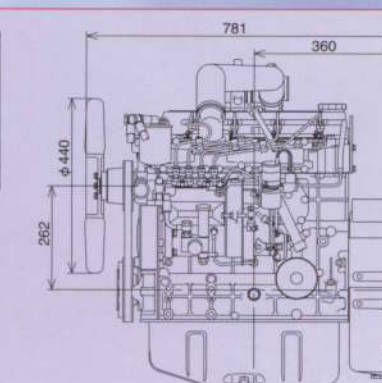
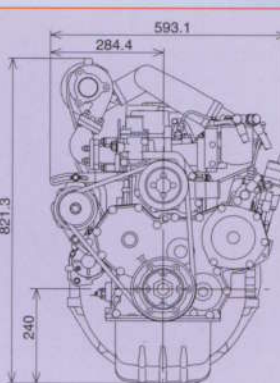

S4S-DT



Flywheel: SAE #11.5
 Flywheel housing: SAE #3

Specification

Item	Model	L2E	L3E	S3L2	S4L2	
Type		4-cycle, water-cooled, diesel engine				
Aspiration		Natural-aspirated				
Number of cylinders		2	3	3	4	
Bore and stroke	mm	76×70	76×70	78×92	78×92	
Displacement	cc	635	952	1318	1758	
Combustion system		Swirl chamber				
Firing order (Electric starting with cell starter)		1-2	1-3-2	1-3-2	1-3-4-2	
Charging alternator	V - A	12 - 40	12 - 40	12 - 50	12 - 50	
Starting system	V - kW	12 - 1.2	12 - 1.7	12 - 1.7	12 - 2.0	
Fuel		Diesel fuel (ASTM No. 2-D)				
Lub. oil capacity	ℓ	2.0	3.1	4.2	6.0	
Dry weight (1500/1800 rpm. spec.)	kg	73	87	135	155	
Generator output (ISO3046, gross*)	50 Hz (1500 rpm)	St-by kW	4.7	7.5	10.8	15.4
		Prime kW	4.0	6.4	9.7	13.8
	60 Hz (1800 rpm)	St-by kW	6.0	9.3	13.4	18.8
		Prime kW	5.1	8.0	12.0	17.0
	50 Hz (3000 rpm)	St-by kW	9.9	15.4	21.2	28.8
		Prime kW	8.5	13.3	18.3	25.8
60 Hz (3600 rpm)	St-by kW	11.3	17.7	—	—	
	Prime kW	9.9	15.6	—	—	
Flywheel		SAE #6.5	SAE #6.5	SAE #7.5	SAE #7.5	
Flywheel housing		SAE #5	SAE #5	SAE #5	SAE #5	
Emission compliance		US EPA Tier 4a		US EPA Tier 4a / EU Stage 2 constant		

Item	Model	S4Q2	S4S	S4S-DT	
Type		4-cycle, water-cooled, diesel engine			
Aspiration		Natural-aspirated	Natural-aspirated	Turbocharged	
Number of cylinders		4	4	4	
Bore and stroke	mm	88×103	94×120	94×120	
Displacement	cc	2505	3331	3331	
Combustion system		Swirl chamber	Swirl chamber	Direct injection	
Firing order (Electric starting with cell starter)		1-3-4-2	1-3-4-2	1-3-4-2	
Charging alternator	V - A	12 - 50	12 - 50	12 - 50	
Starting system	V - kW	12 - 2.0	12 - 2.2	12 - 2.2	
Fuel		Diesel fuel (ASTM No. 2-D)			
Lub. oil capacity	ℓ	6.5	10.0	10.0	
Dry weight (1500/1800 rpm. spec.)	kg	195	245	250	
Generator output (ISO3046, gross*)	50 Hz (1500 rpm)	St-by kW	21.0	31.6	39.0
		Prime kW	19.5	28.7	37.5
	60 Hz (1800 rpm)	St-by kW	25.0	36.5	46.2
		Prime kW	23.5	34.2	44.5
Flywheel		SAE #7.5	SAE #11.5	SAE #11.5	
Flywheel housing		SAE #4	SAE #3	SAE #3	
Emission compliance		US EPA Tier 4a / EU Stage 2 constant		US EPA Tier 2 / EU Stage 2 constant	

Note *: The out put of the basic engine without such accessories as air cleaner, fan, radiator, muffler, dynamo etc.



Please read the accompanying instruction manual and all caution labels before operating equipment. The specification described in this catalog is subject to change without prior notice.

MITSUBISHI HEAVY INDUSTRIES, LTD.

General Machinery & Special Vehicle Headquarters
3000, Tana, Sagami-hara, Kanagawa Prefecture 229-1193, Japan
Phone: 81-42-761-2823 Fax: 81-42-763-0814 E-mail: jik100@mhi.co.jp



To protect the environment, this brochure is printed on 100% recycled paper with soy inks, by a waterless printing method that generates no harmful wastewater.



MITSUBISHI ENGINE NORTH AMERICA, INC.

1250 Greenbriar Drive, Suite E Addison, IL 60101-1098, U.S.A
Phone: 1-630-268-0750 Fax: 1-630-268-9293

MHI EQUIPMENT EUROPE B.V.

Damsluisweg 2, 1332 EC, Almere, The Netherlands
Phone: 31-36-538-8327 Fax: 31-36-538-8342

MHI ENGINE SYSTEM ASIA PTE. LTD.

No. 2, Tuas Avenue 20, Singapore 638818, Republic of Singapore
Phone: 65-6862-2202 Fax: 65-6862-5728